



Санкт-Петербургский государственный университет
промышленных технологий и дизайна

Проектирование промышленных изделий

3D industrial design

SWANN

Беспроводные наушники

КОНЦЕПТ

SWAN

— это эстетический концепт наушников, вдохновлённый образом лебедя: лёгкостью, грацией и чистотой.



СКЕТЧИ И ВАРИАНТЫ

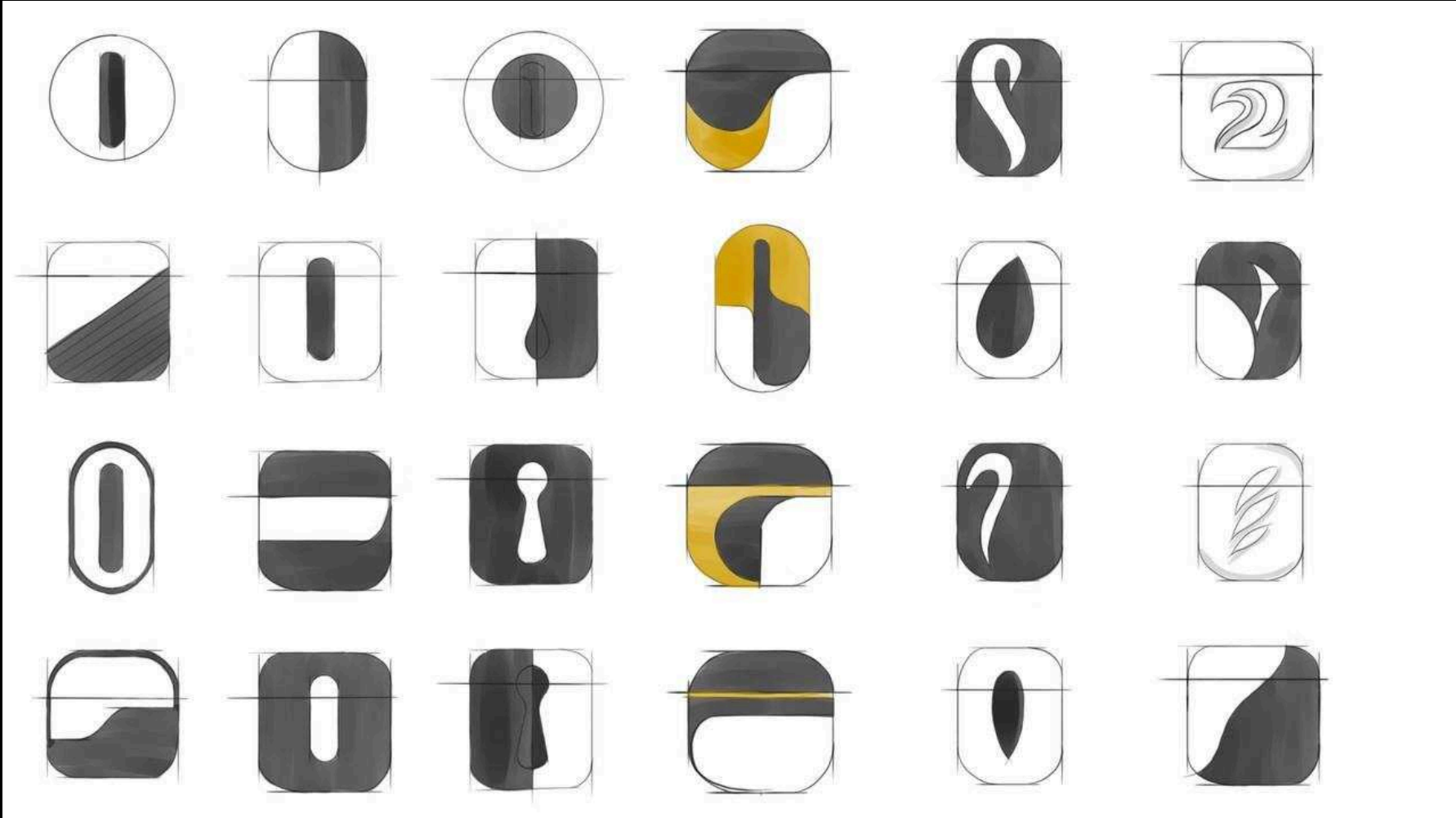
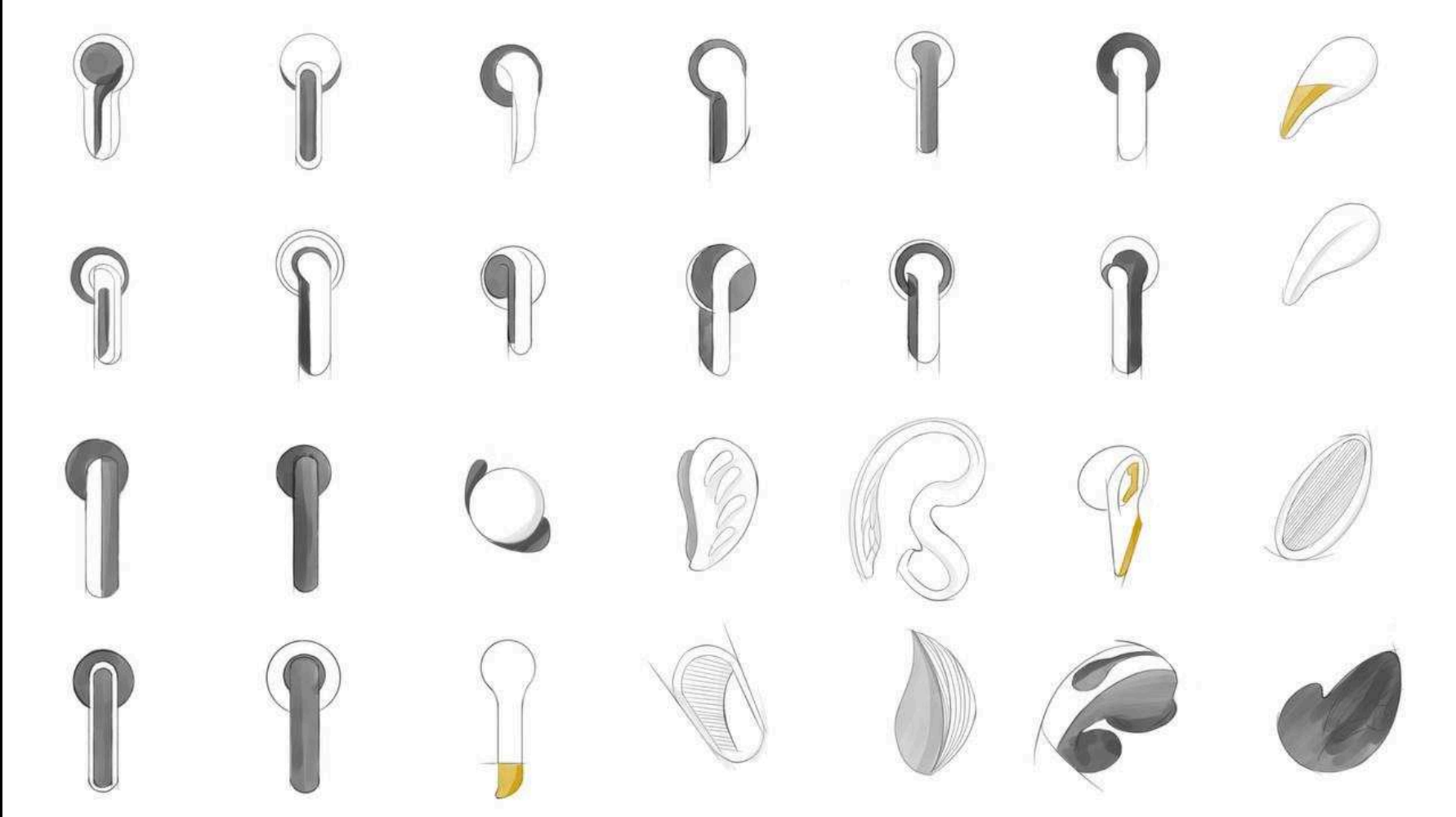

ИТОГОВАЯ МОДЕЛЬ



ИТОГОВАЯ МОДЕЛЬ

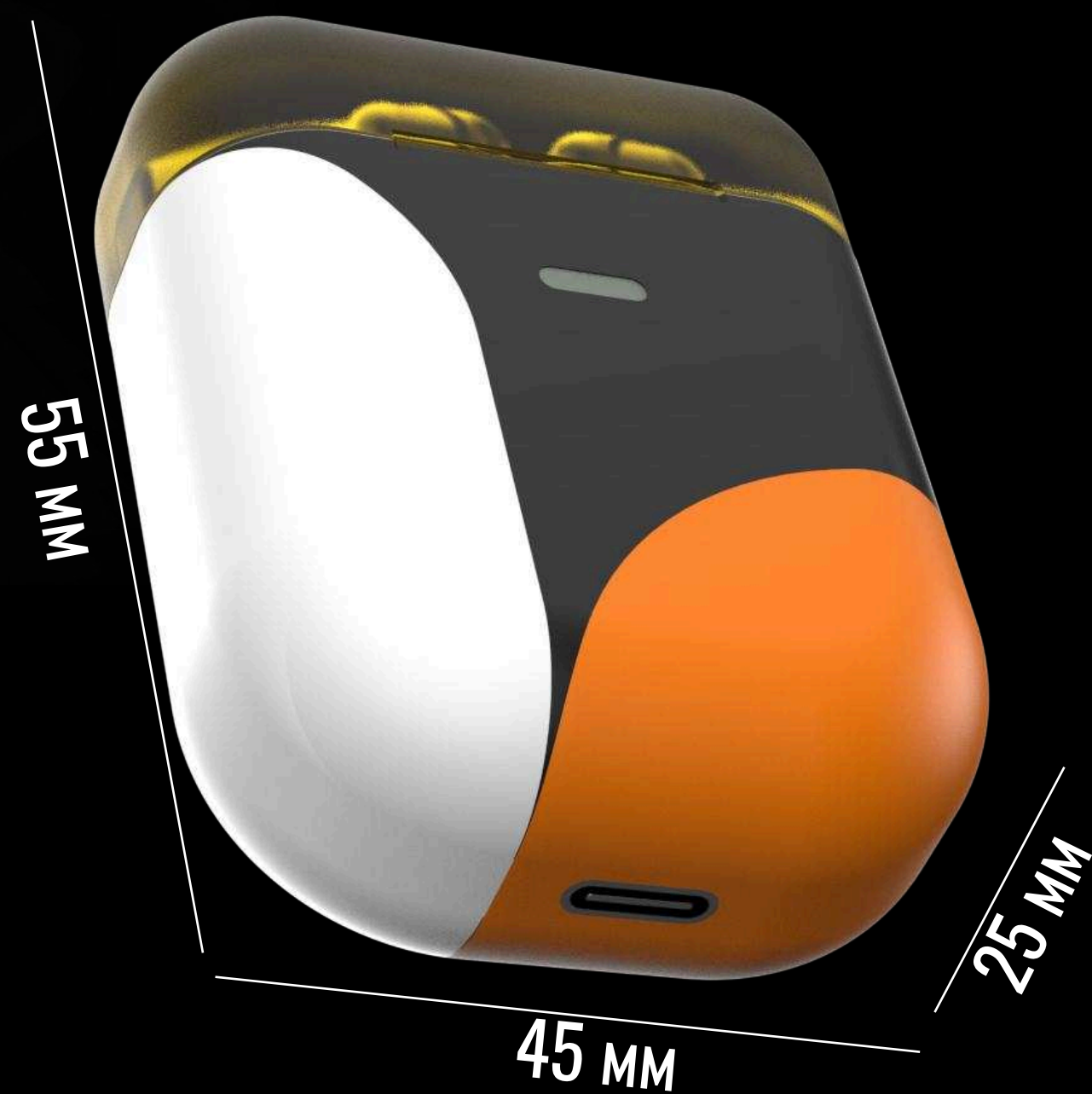

КОНСТРУКЦИЯ

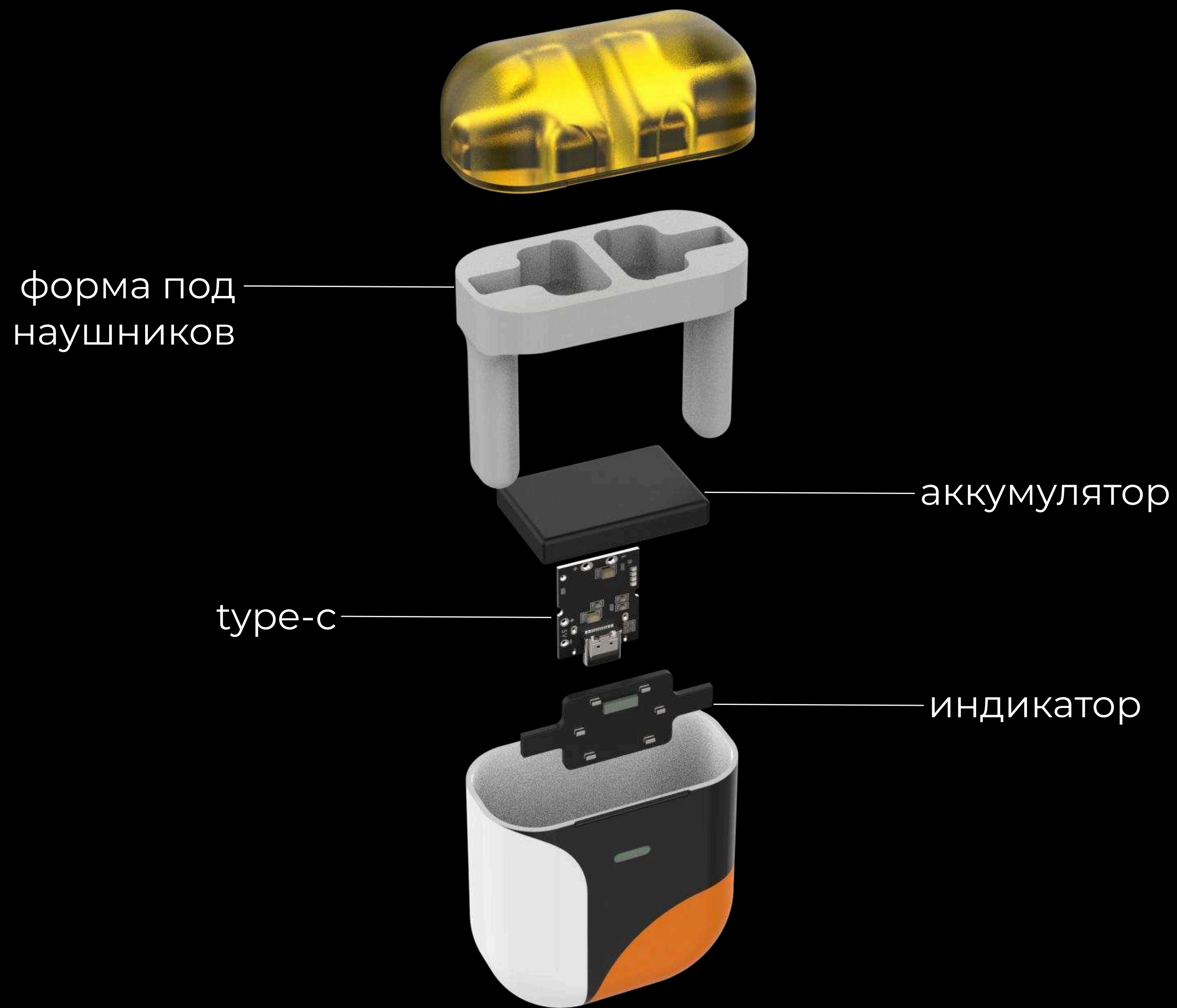

В СРЕДЕ





GEOSCAN

Беспилотные технологии для профессионалов



ЦЕЛЬ

1. Снижение сложности сборки и ремонта БВС
2. Повышение уровня унификации изделия
3. Пересмотр внешнего вида БВС

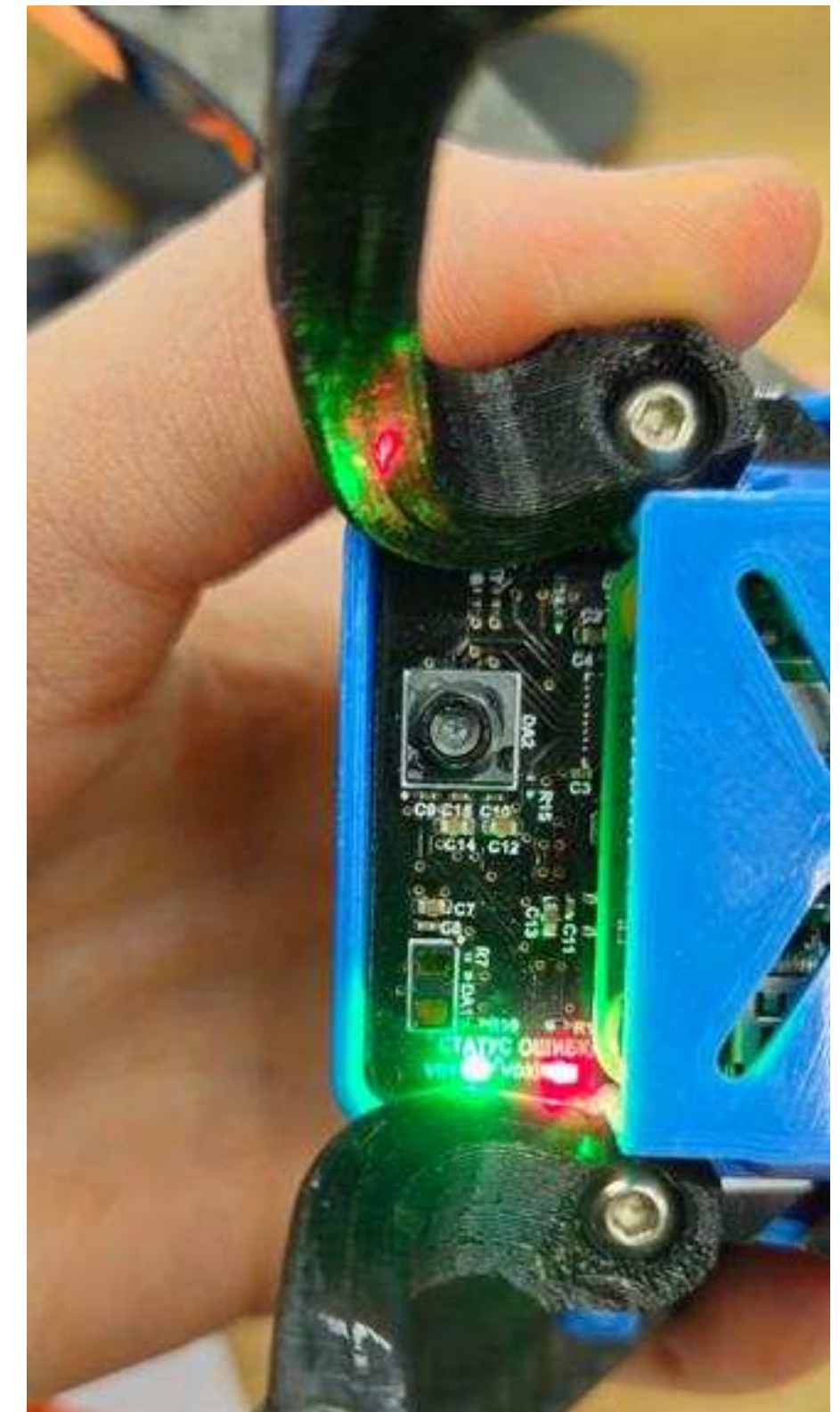
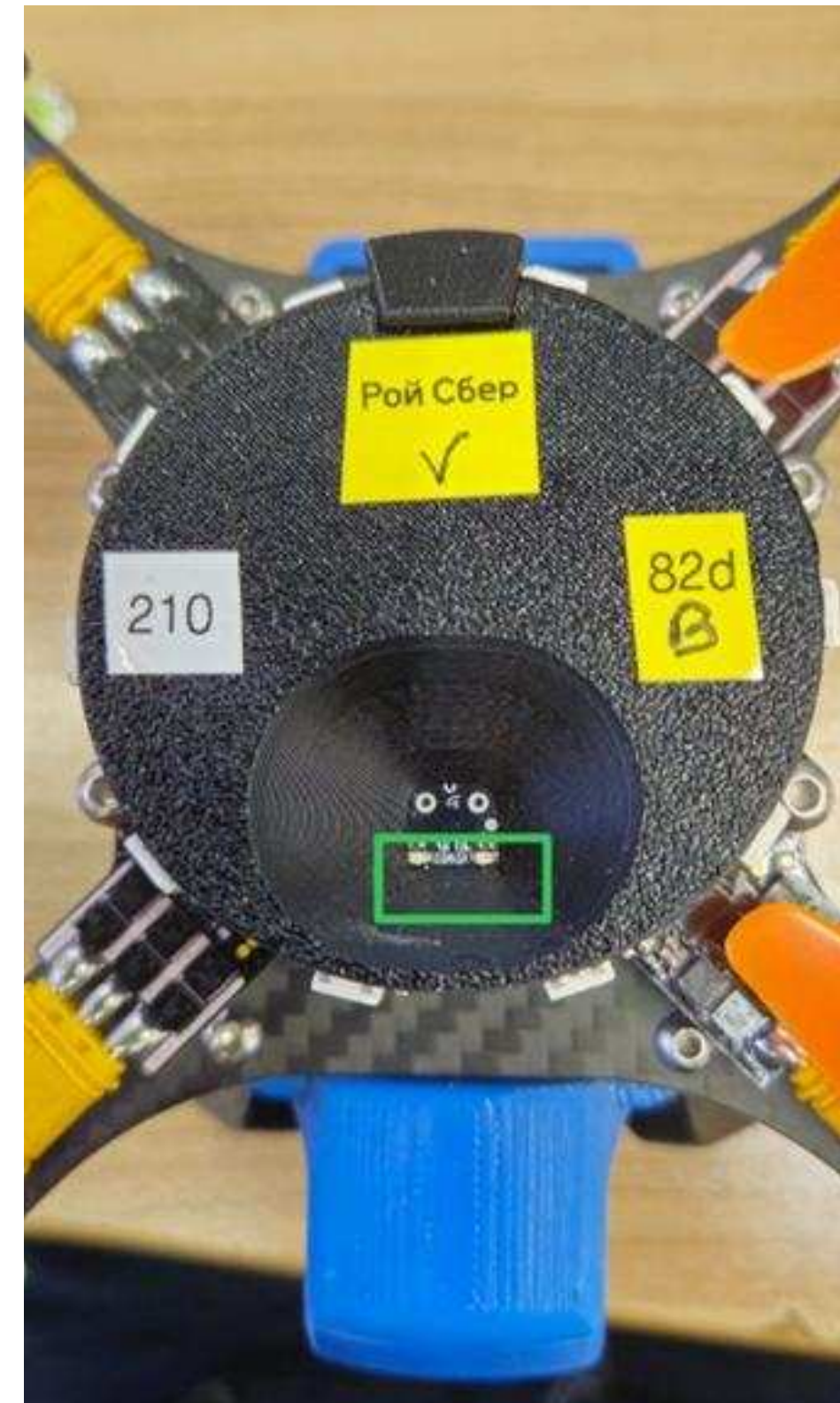

СКЕТЧИ И ВАРИАНТЫ

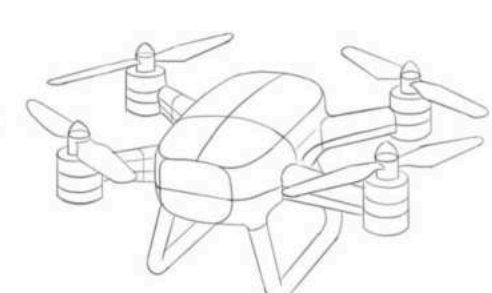
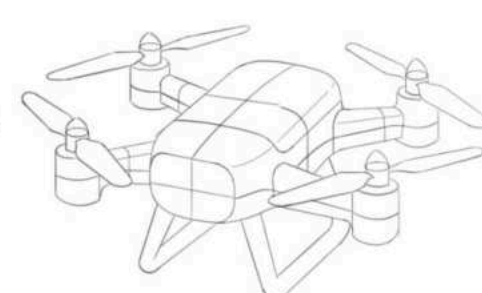
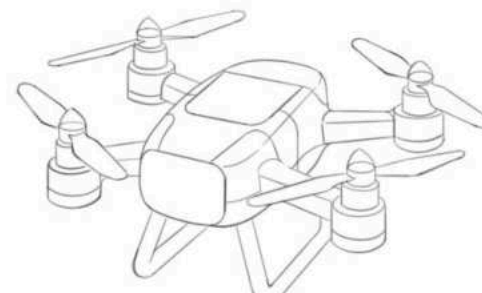
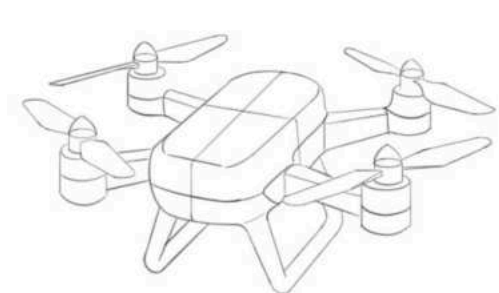
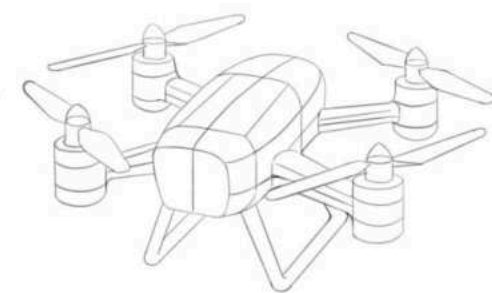
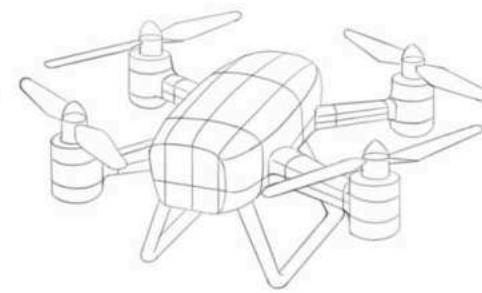
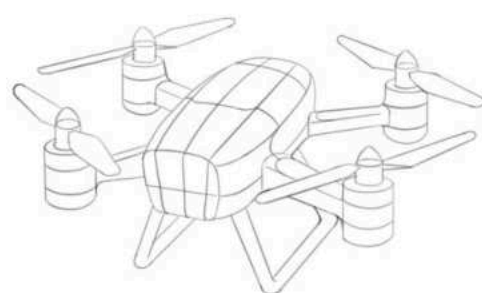
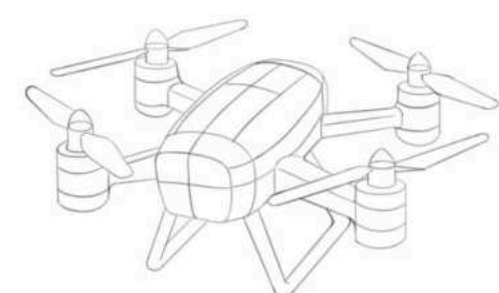
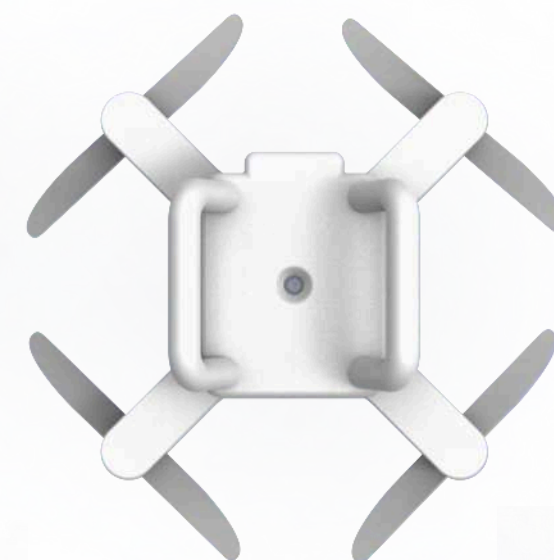
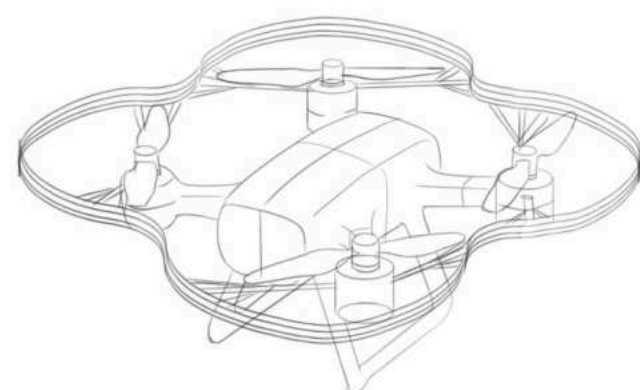
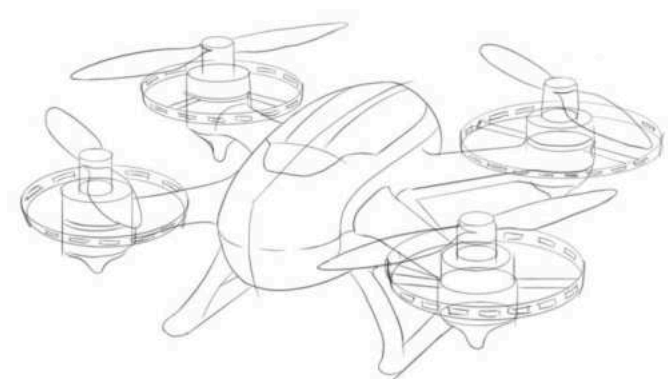
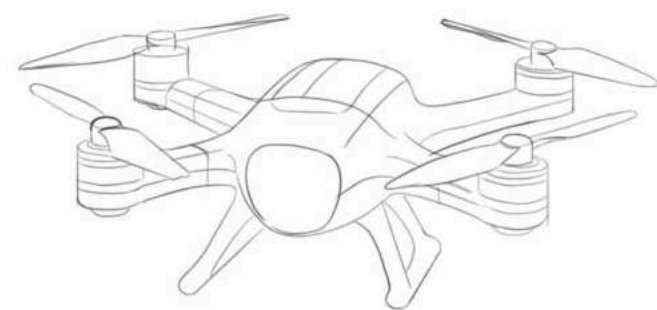

1 2 3

ИТОГОВАЯ МОДЕЛЬ

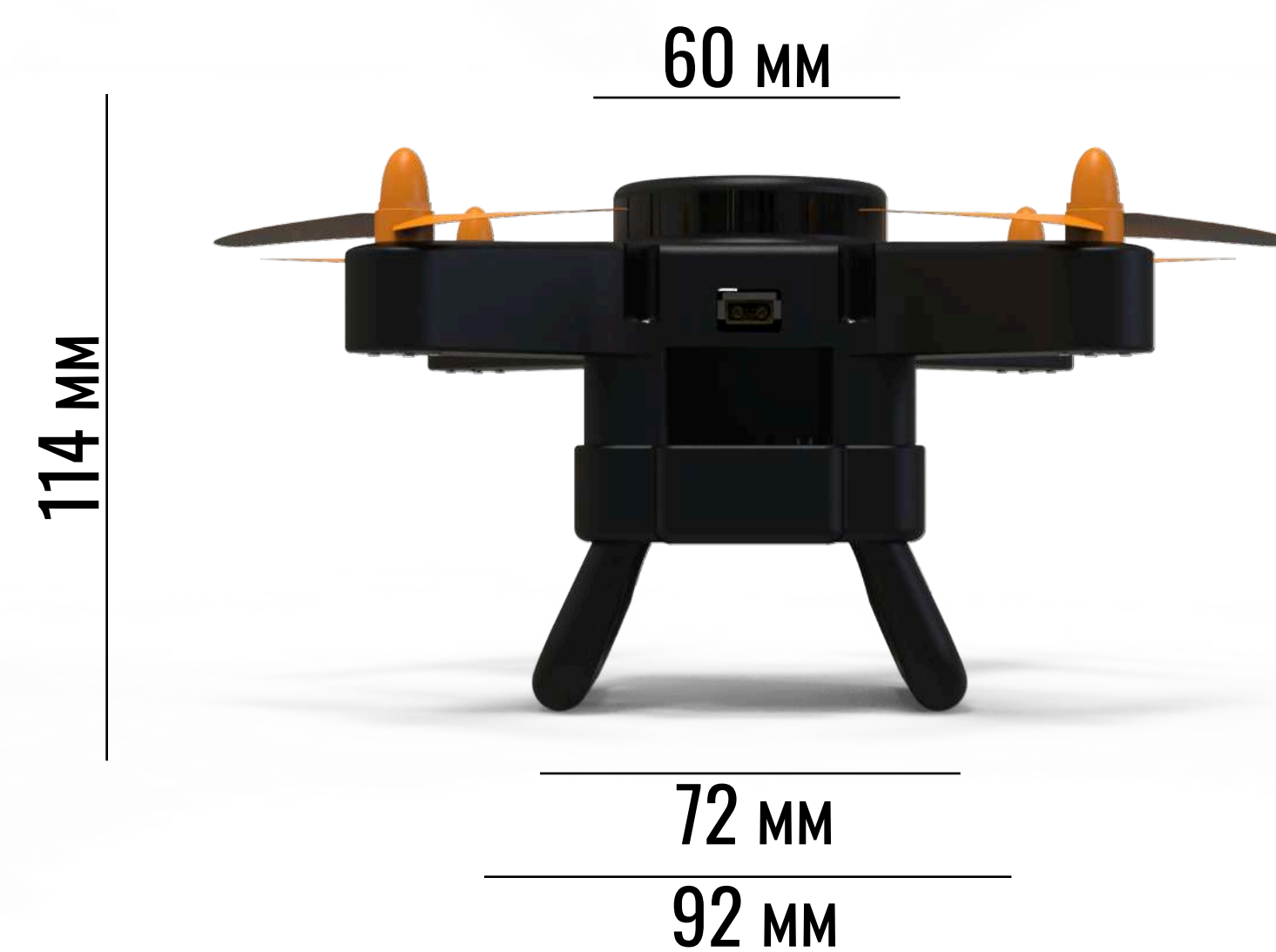



Внутри: модуль/микросхема

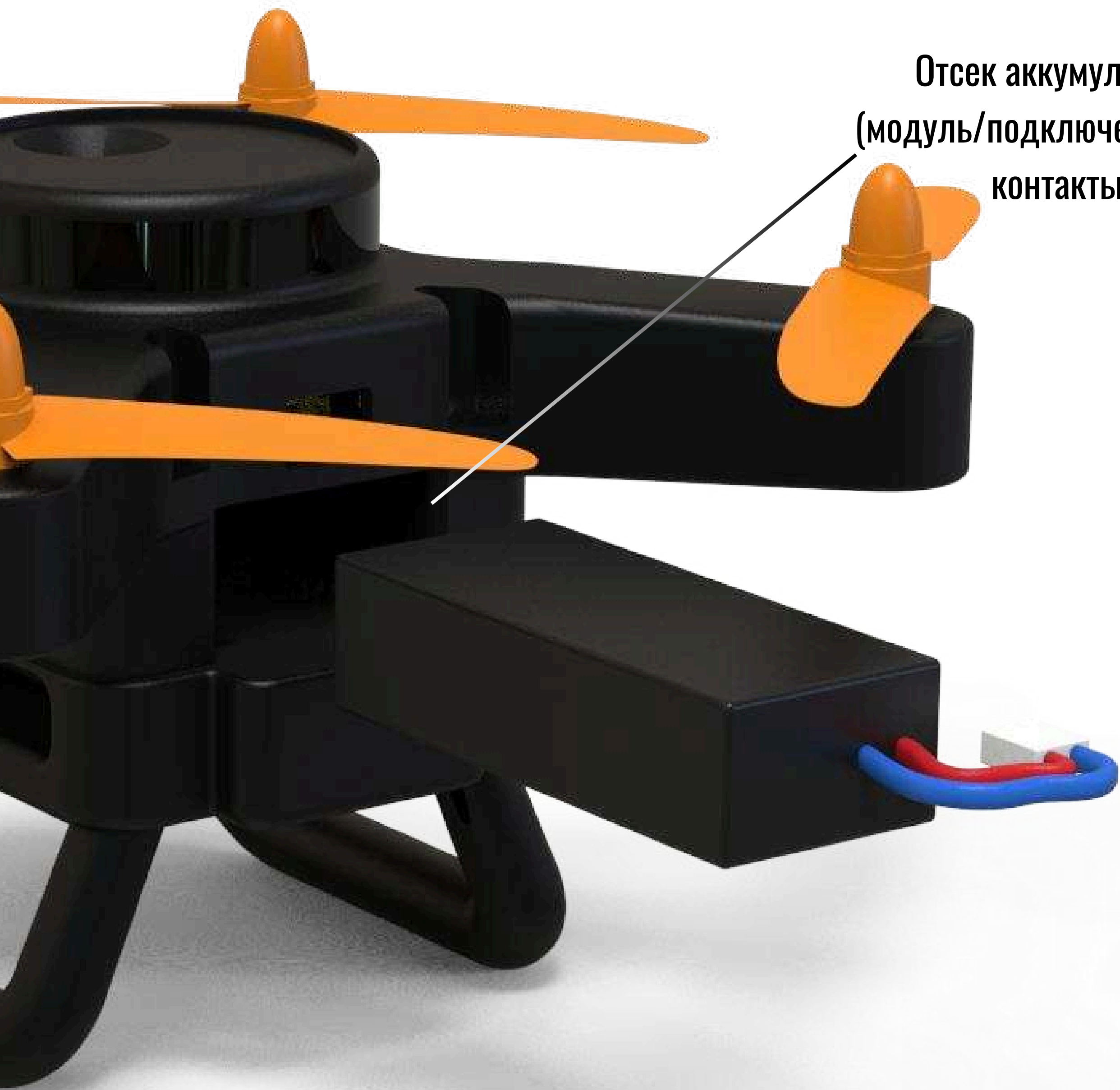

Отсек аккумулятора
(модуль/подключение через
контакты)





Окно нижнего модуля (камера/датчик)



Сервисный отсек: доступ к портам/слотам



Светодиодная лента (LED)



КОНСТРУКЦИЯ

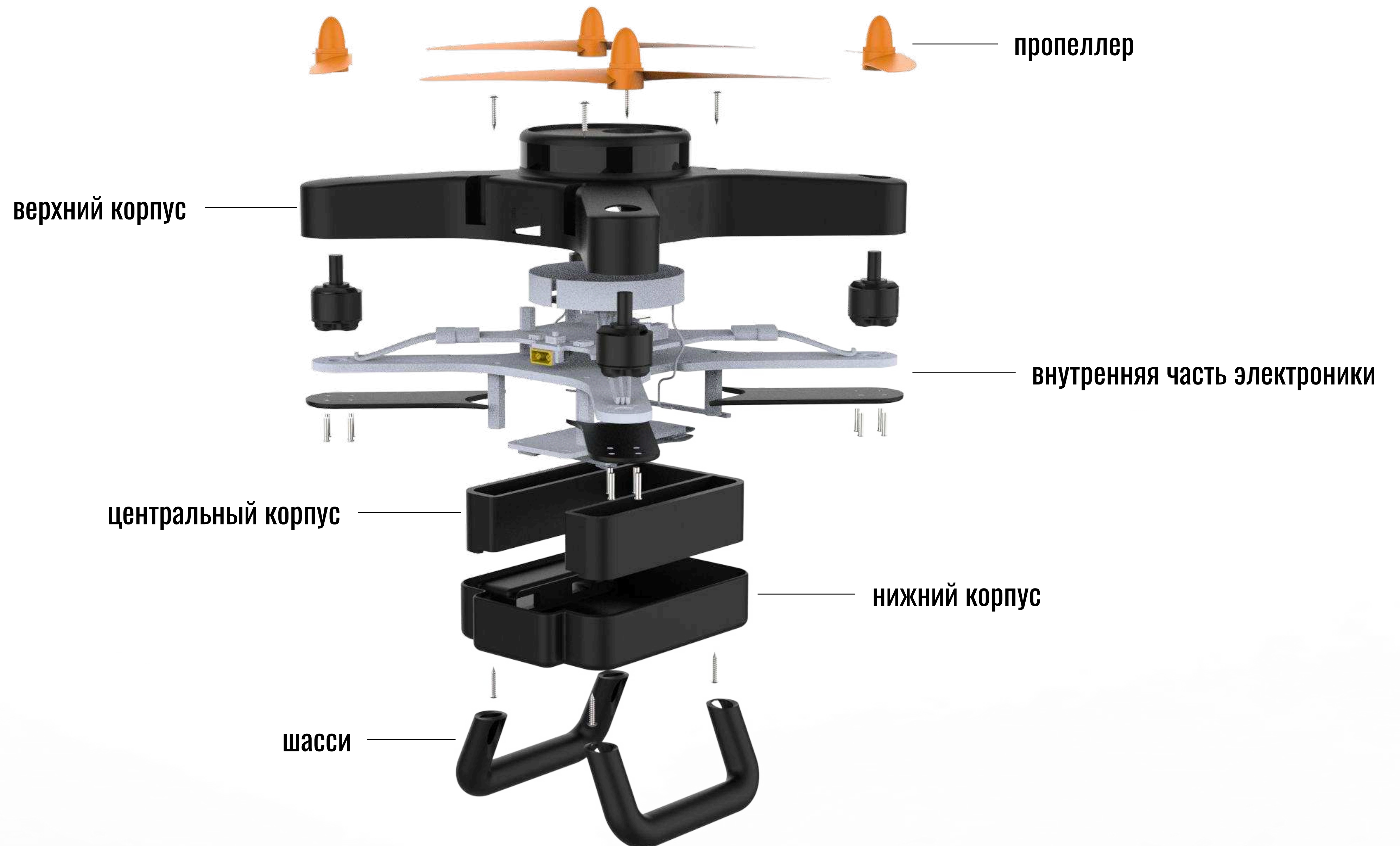

ЦВЕТОГРАФИКА



8

9

10

В СРЕДЕ



MUTEA

Модульная переговорная кабинка



СФЕРЫ ПРИМЕНЕНИЯ

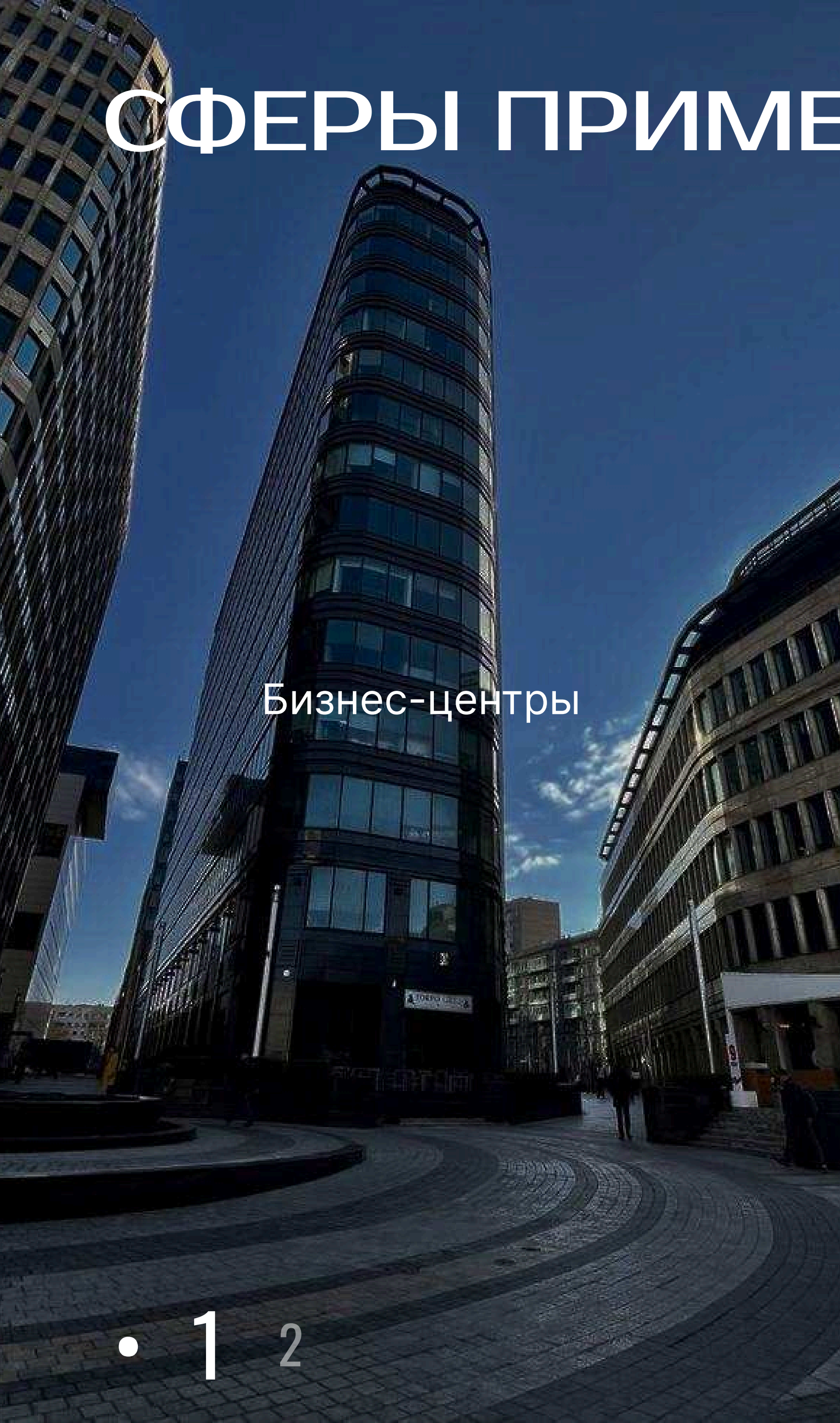

Бизнес-центры



Коворкинги

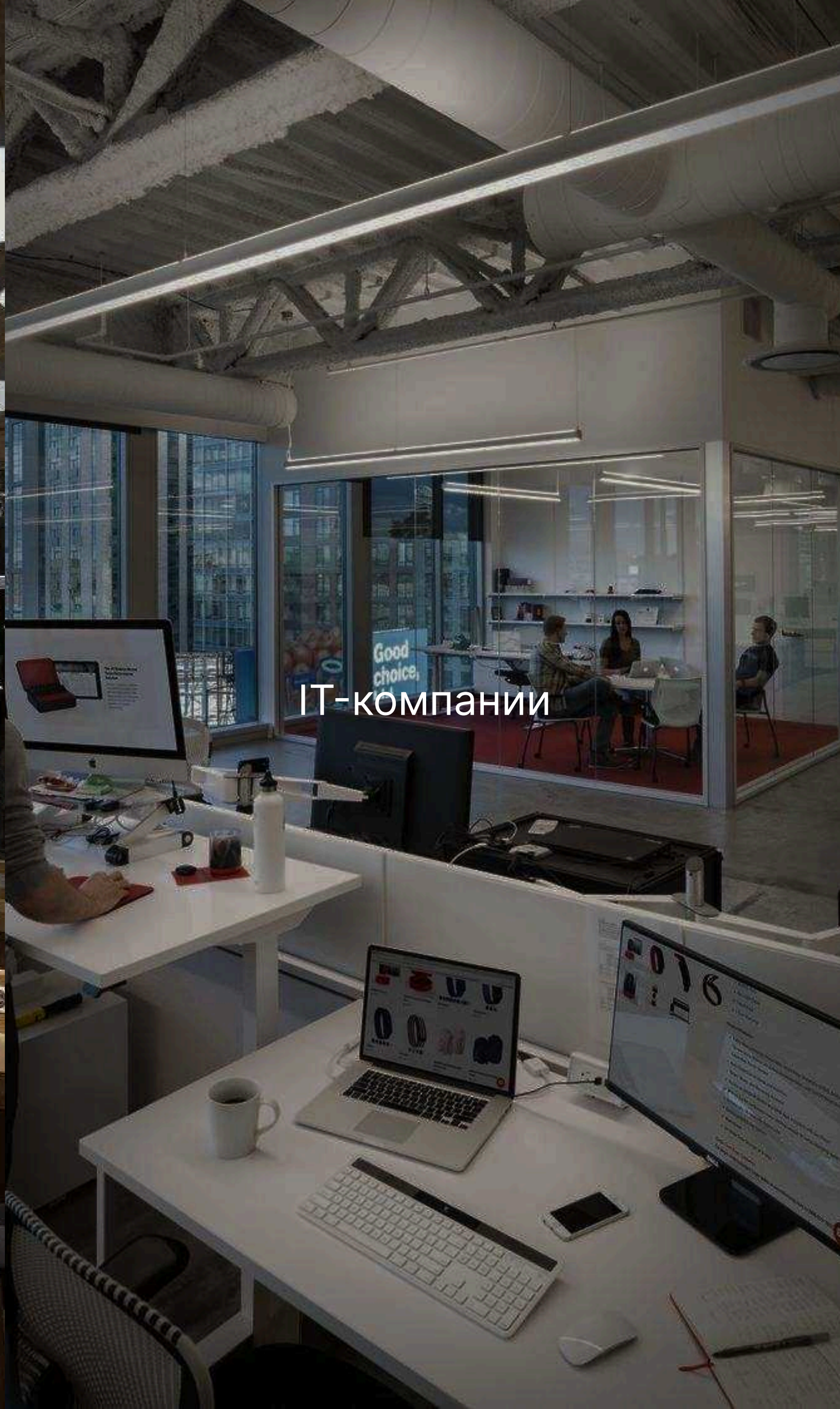

IT-компании

ПРОБЛЕМА

Традиционные переговорные кабины имеют фиксированный размер и форму, поэтому плохо адаптируются под разные сценарии: от короткого созвона на одного человека до мини-встречи на двоих–троих.

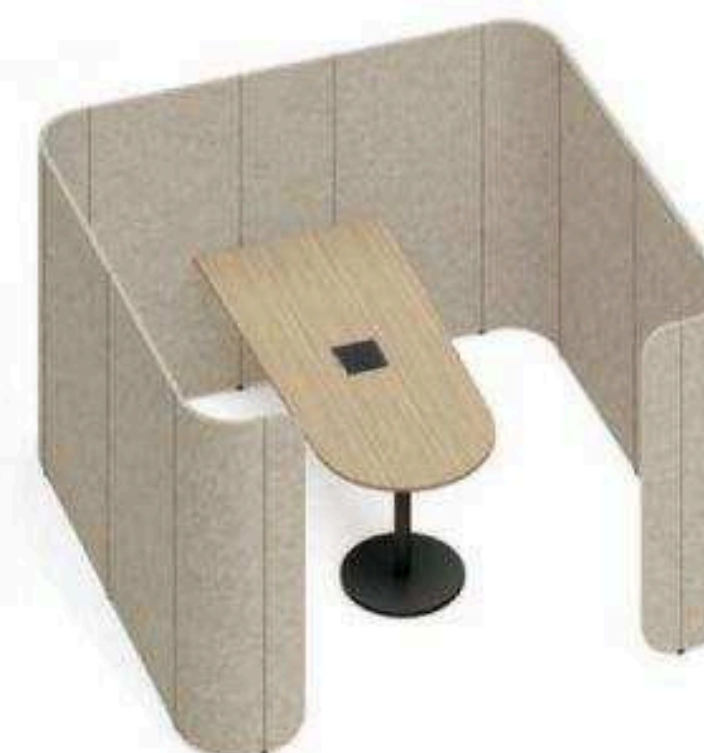

КОНЦЕПЦИЯ

MUTEA

— модульная трансформируемая кабина, которая меняет конфигурацию под задачу: складывается в компактный формат для индивидуальной работы и расширяется за счёт добавления/перестановки сегментов, создавая более открытую или более закрытую зону.

2 3 4

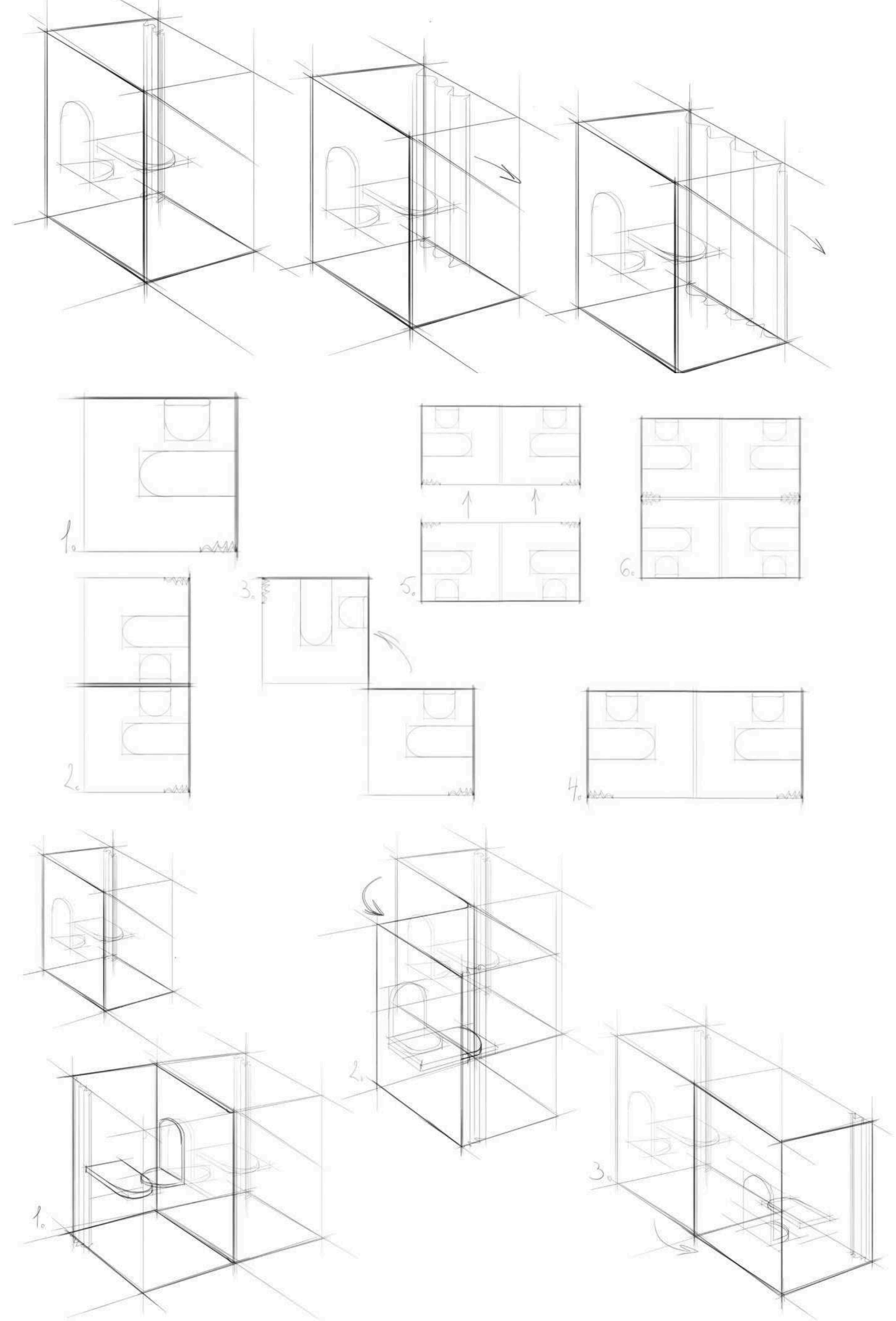

СКЕТЧИ И ВАРИАНТЫ

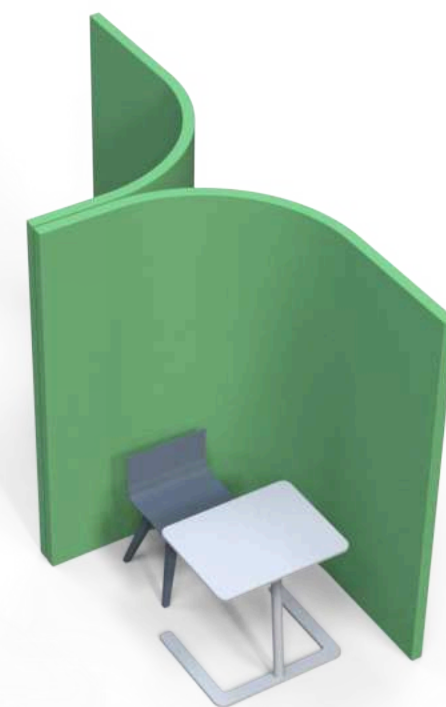
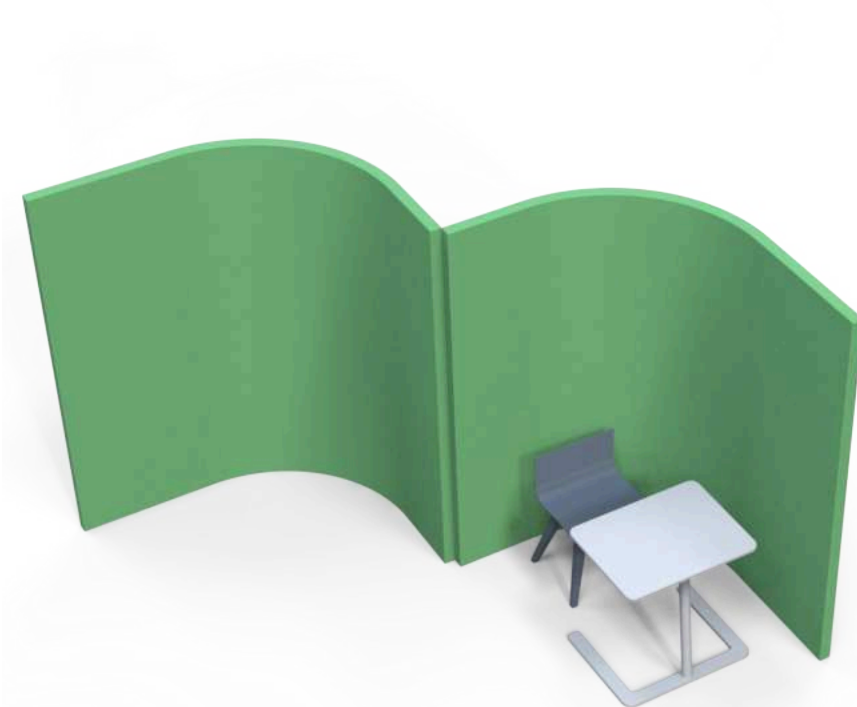
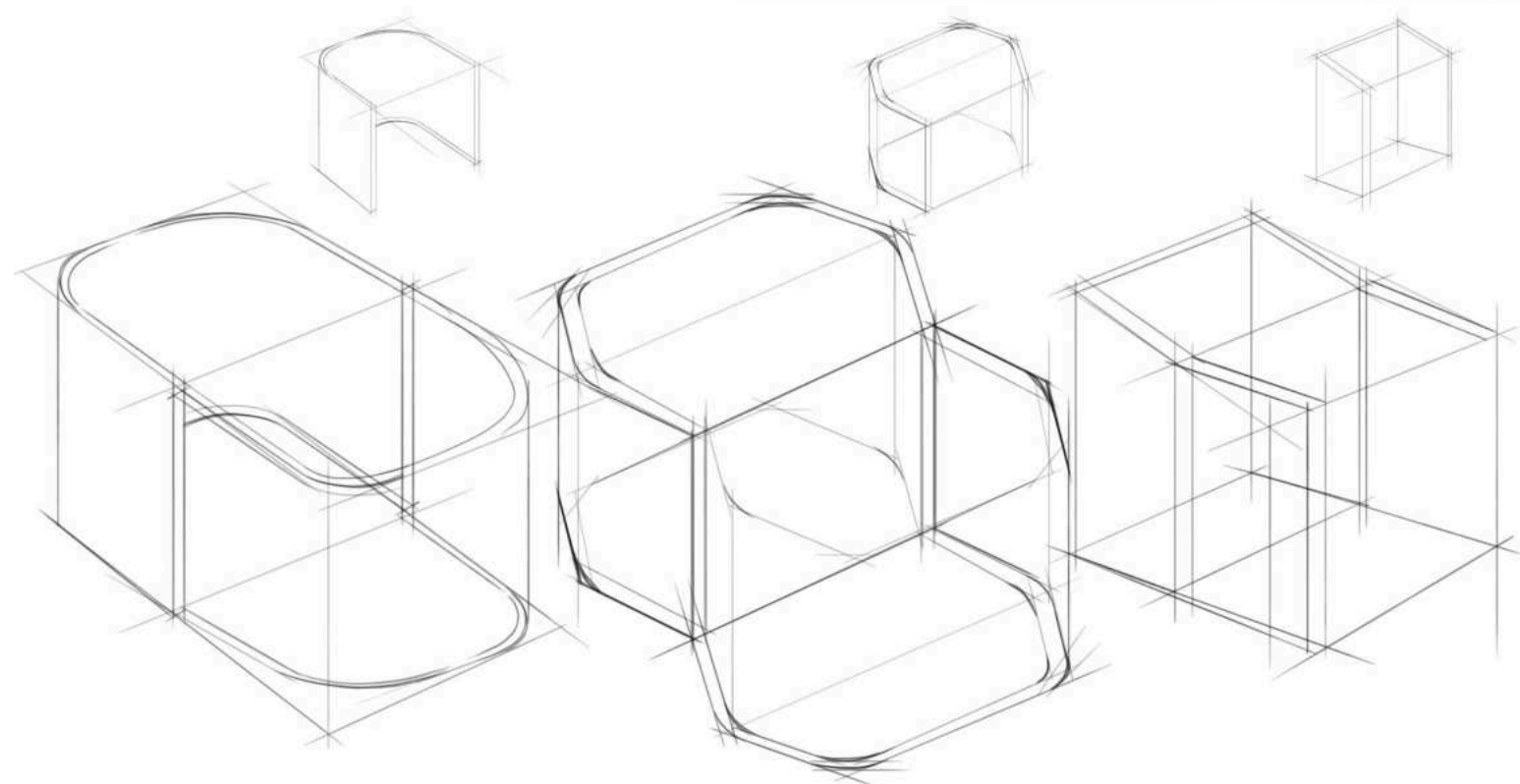
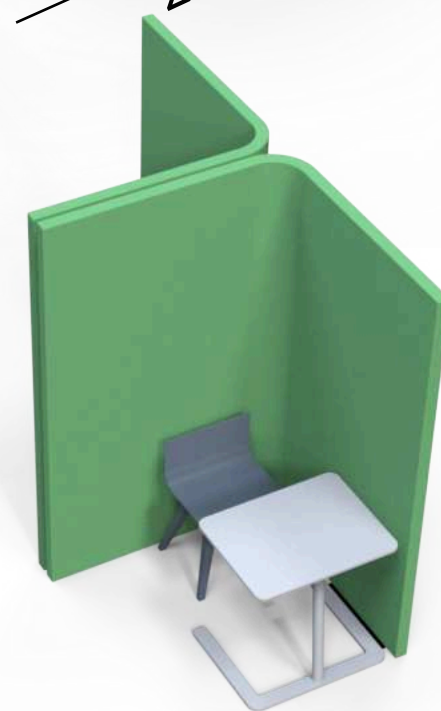
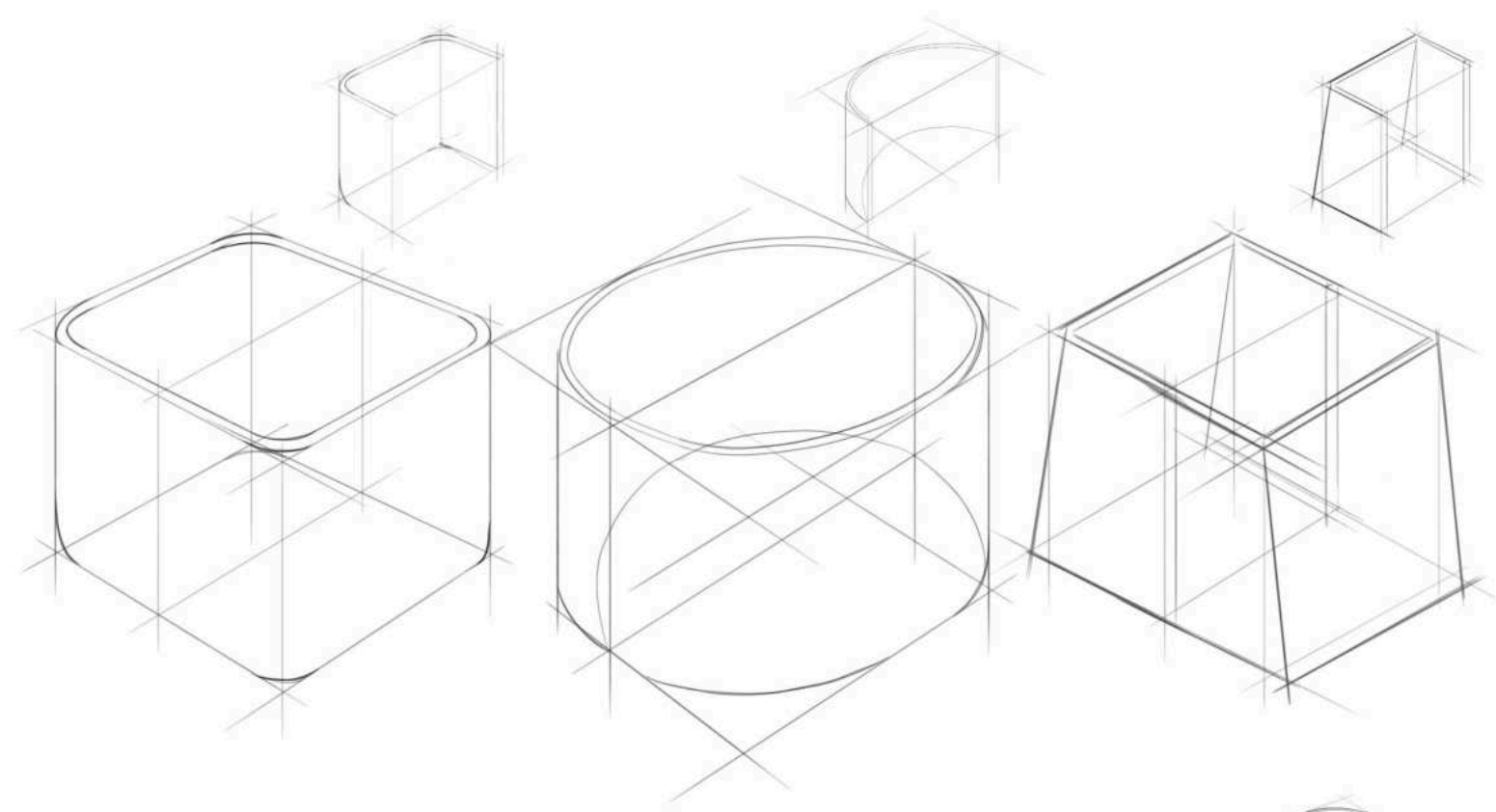
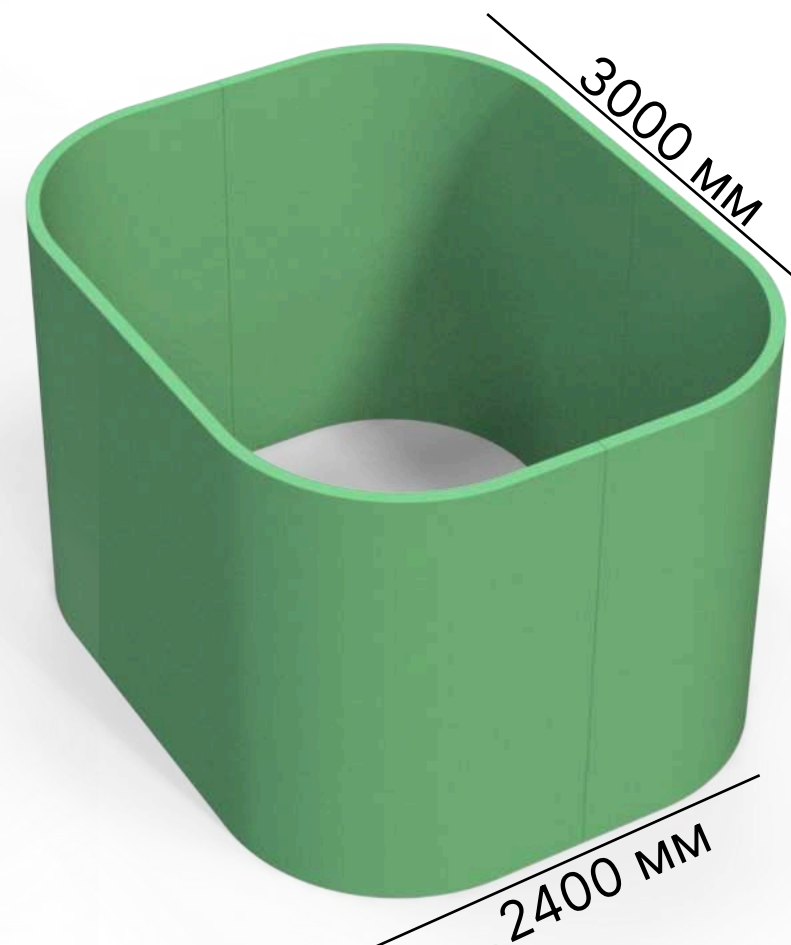
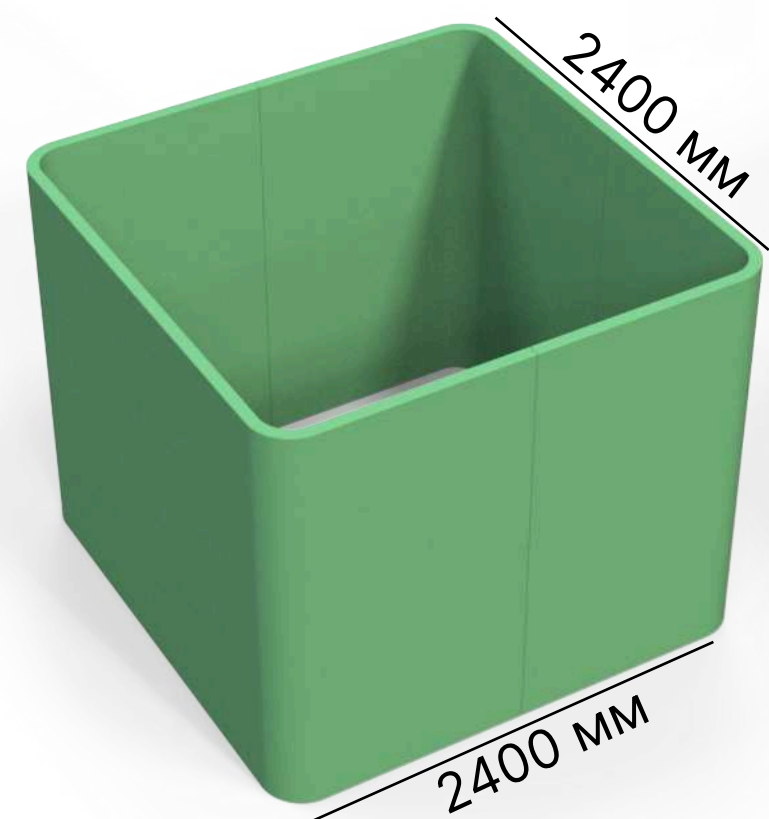
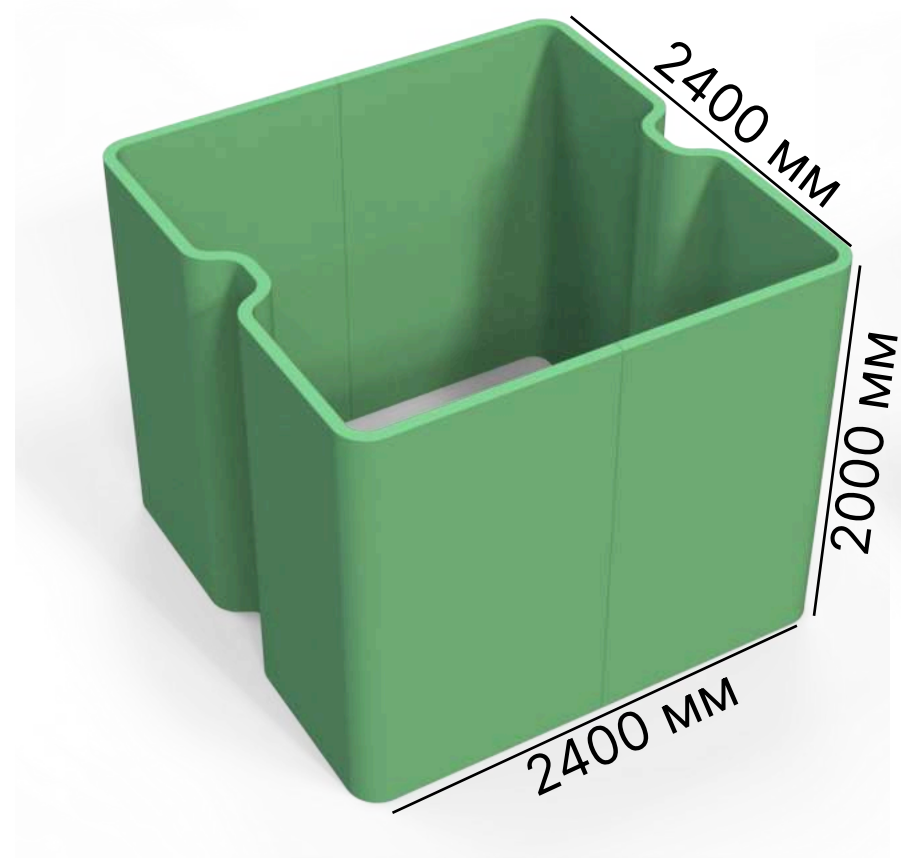
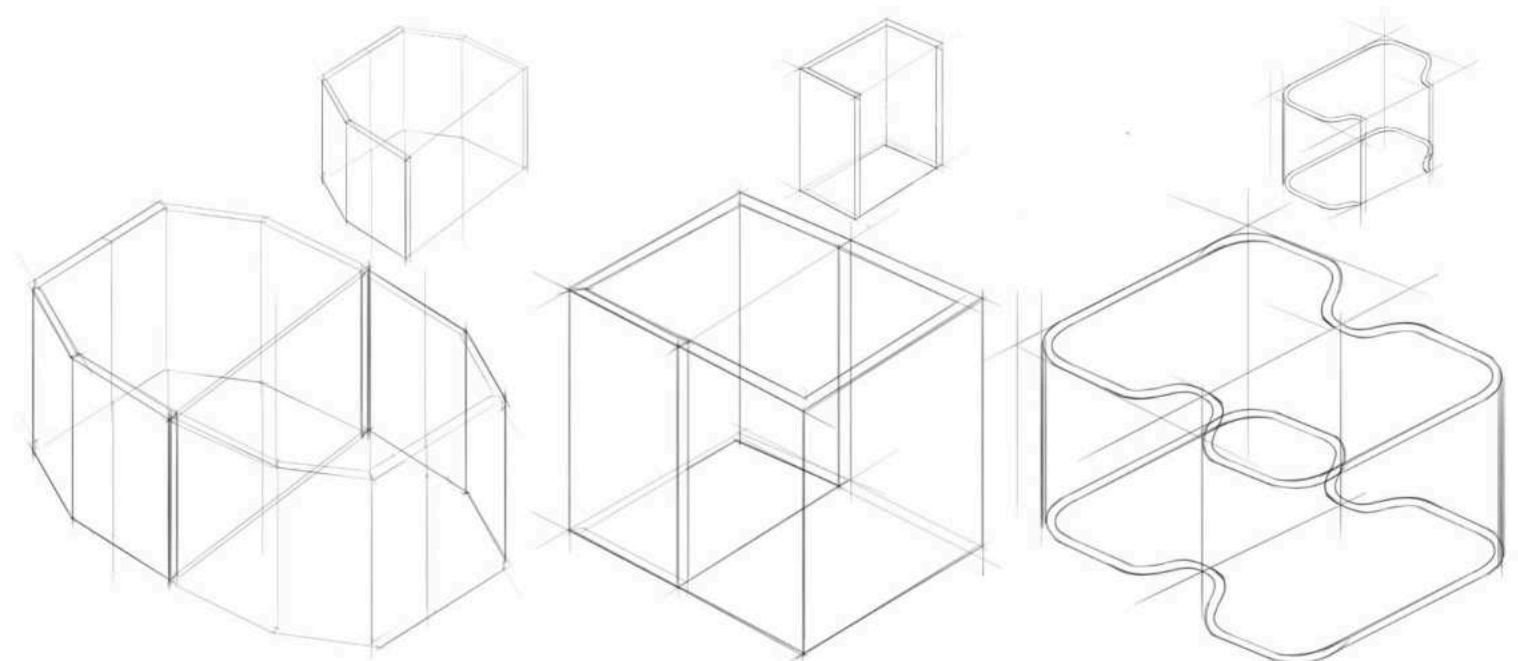

ИТОГОВАЯ МОДЕЛЬ



4 5 6

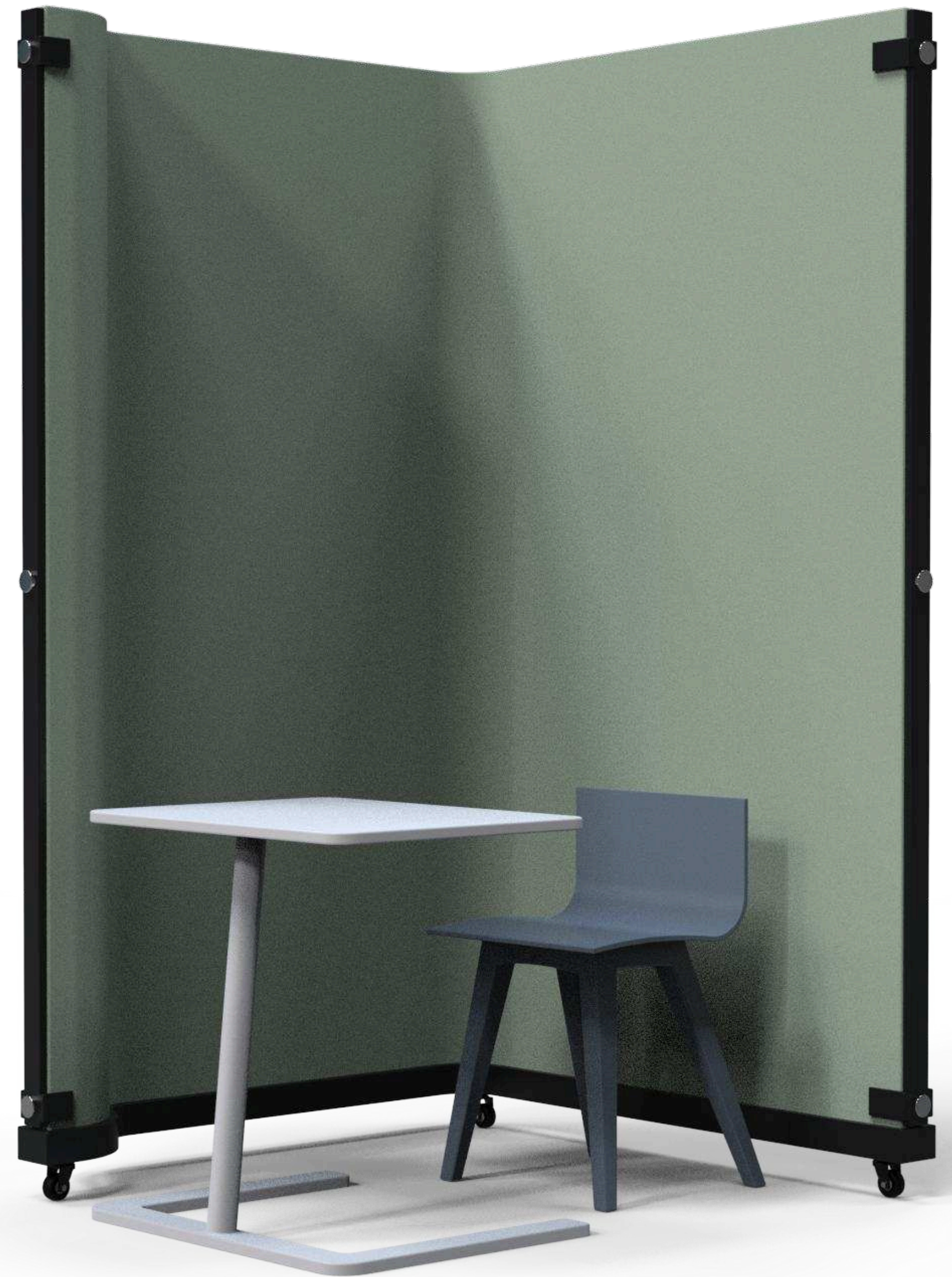

5

6

7

2122,75

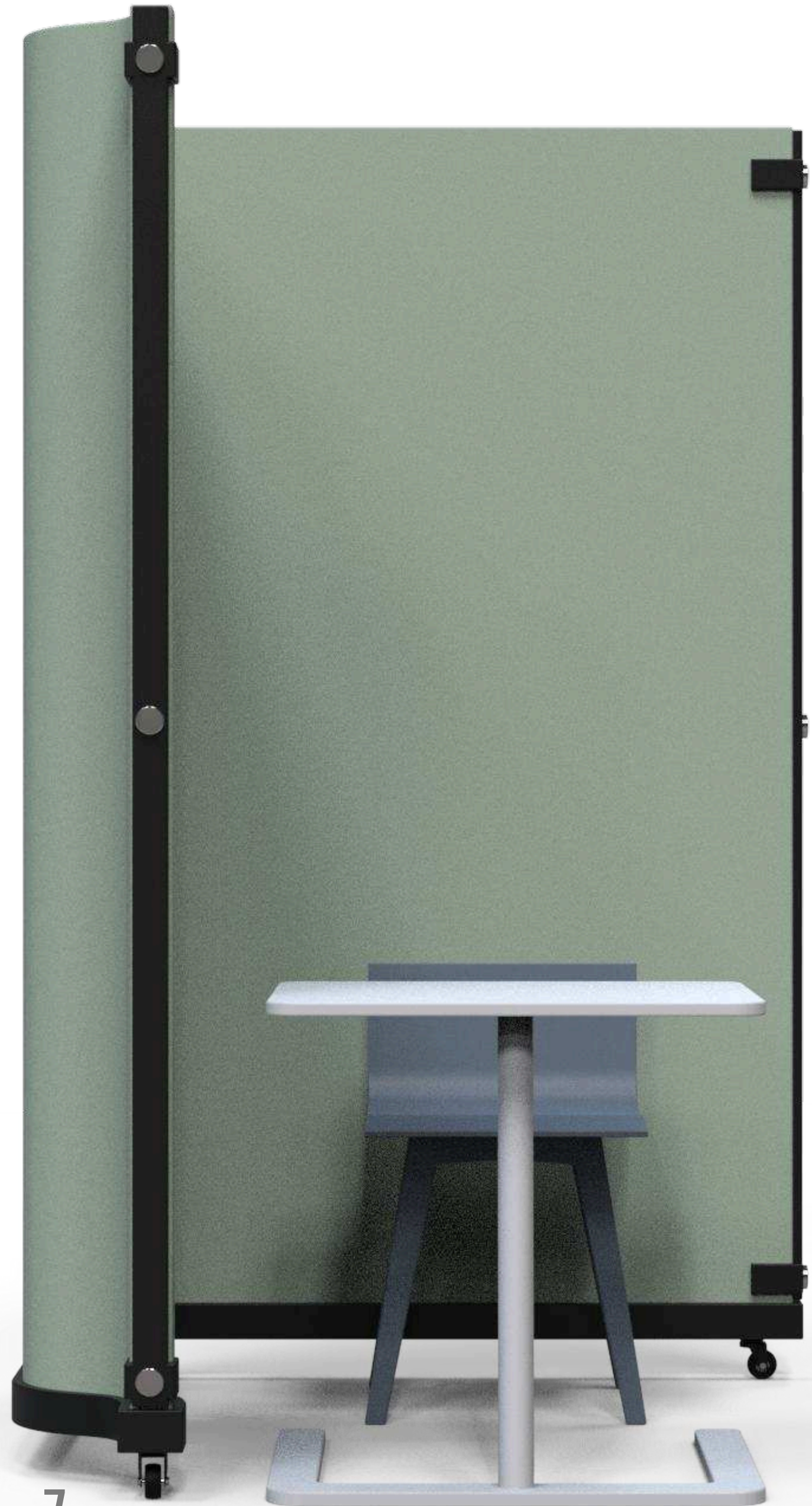

2000 MM

1200 MM

1200 MM

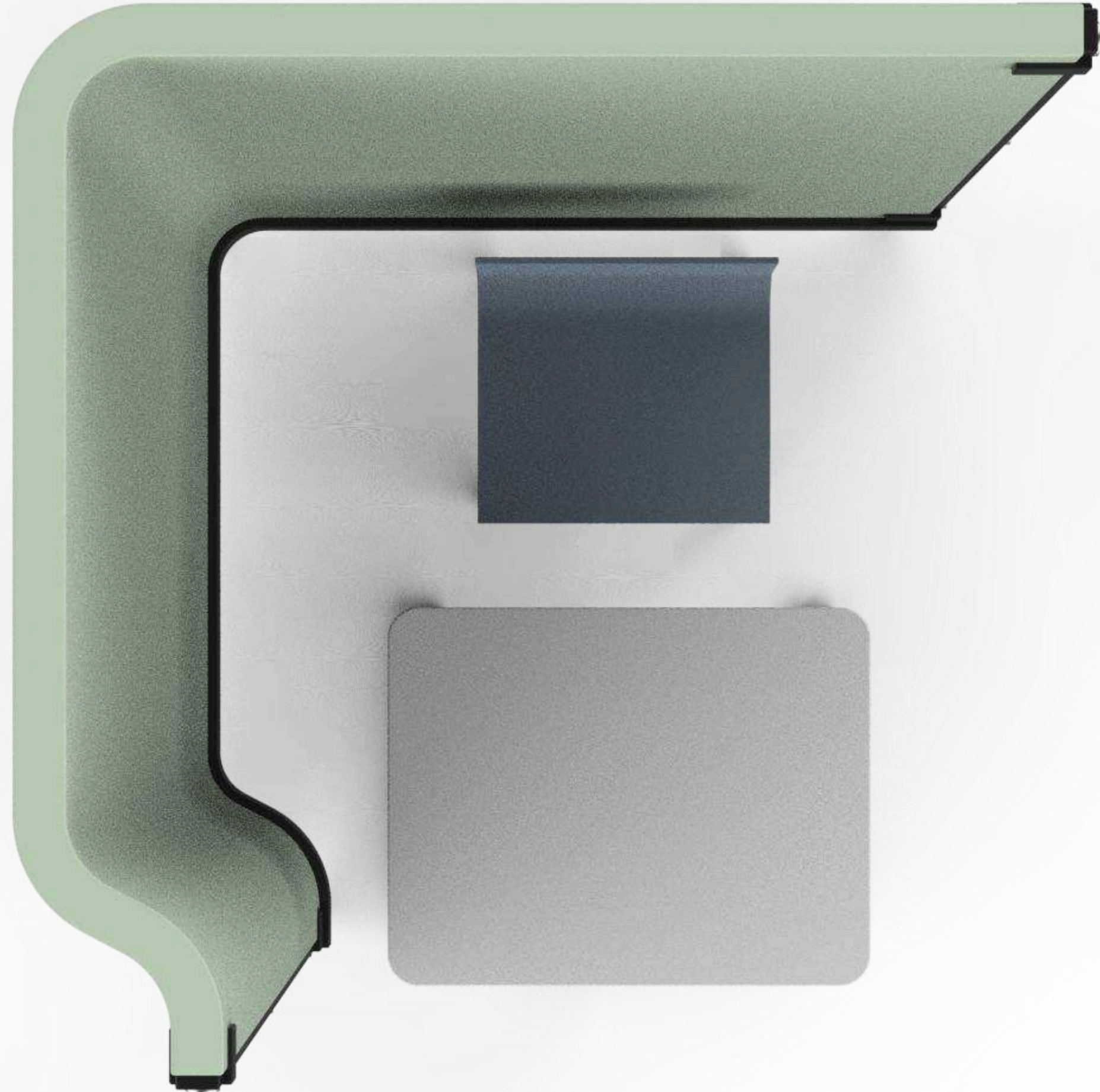



магниты для
присоединения с
другими
кабинками

колесики для передвижения

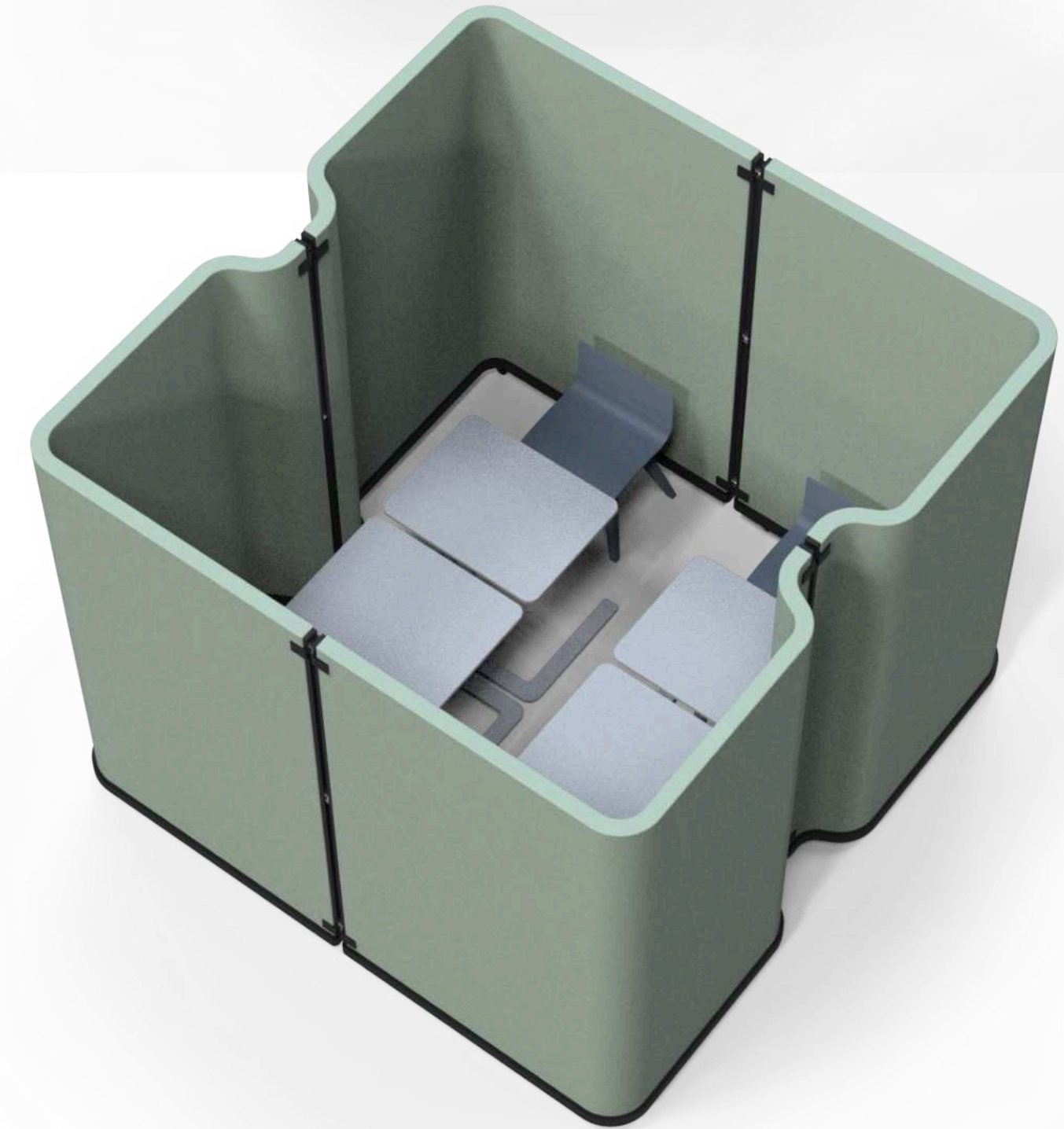
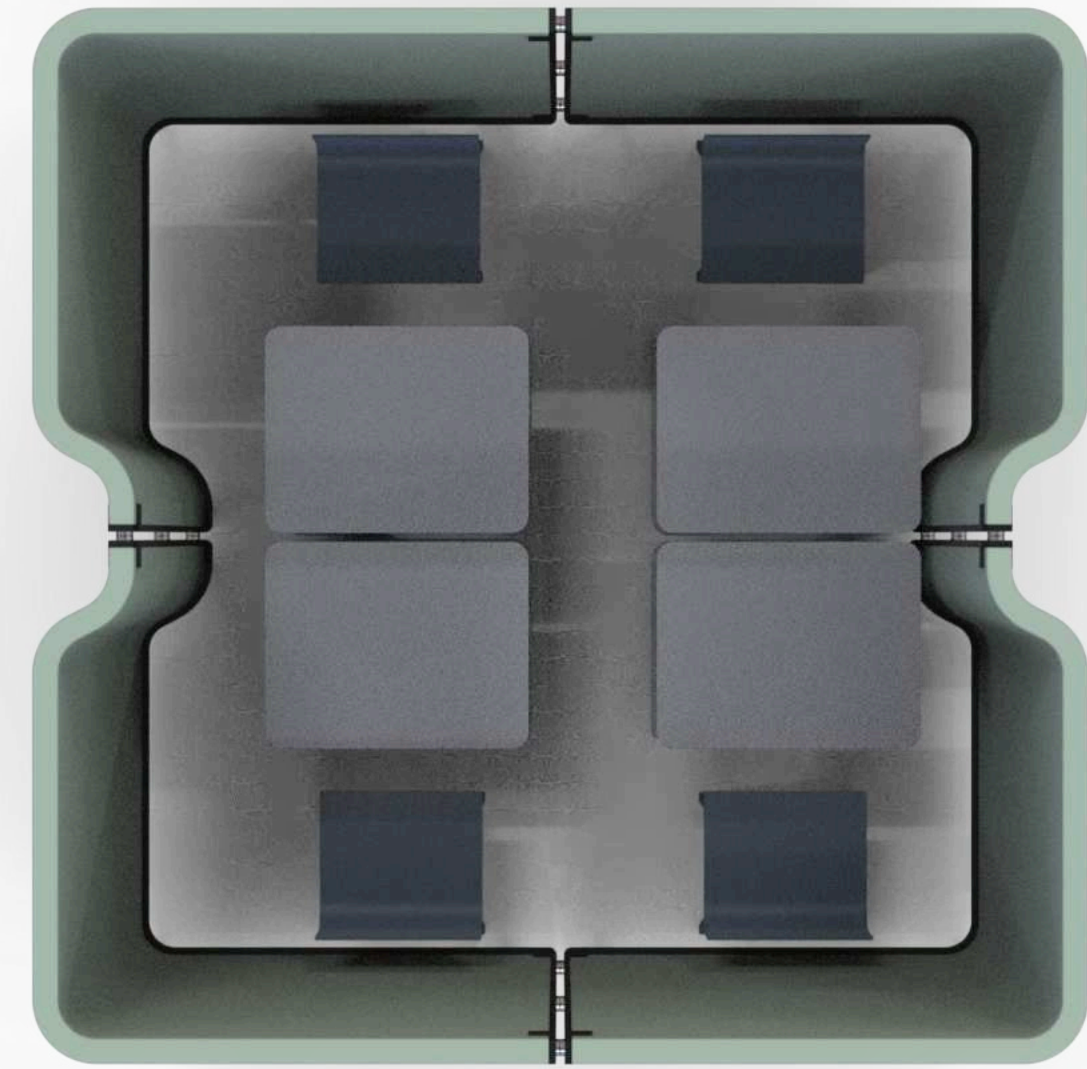

КОНСТРУКЦИЯ

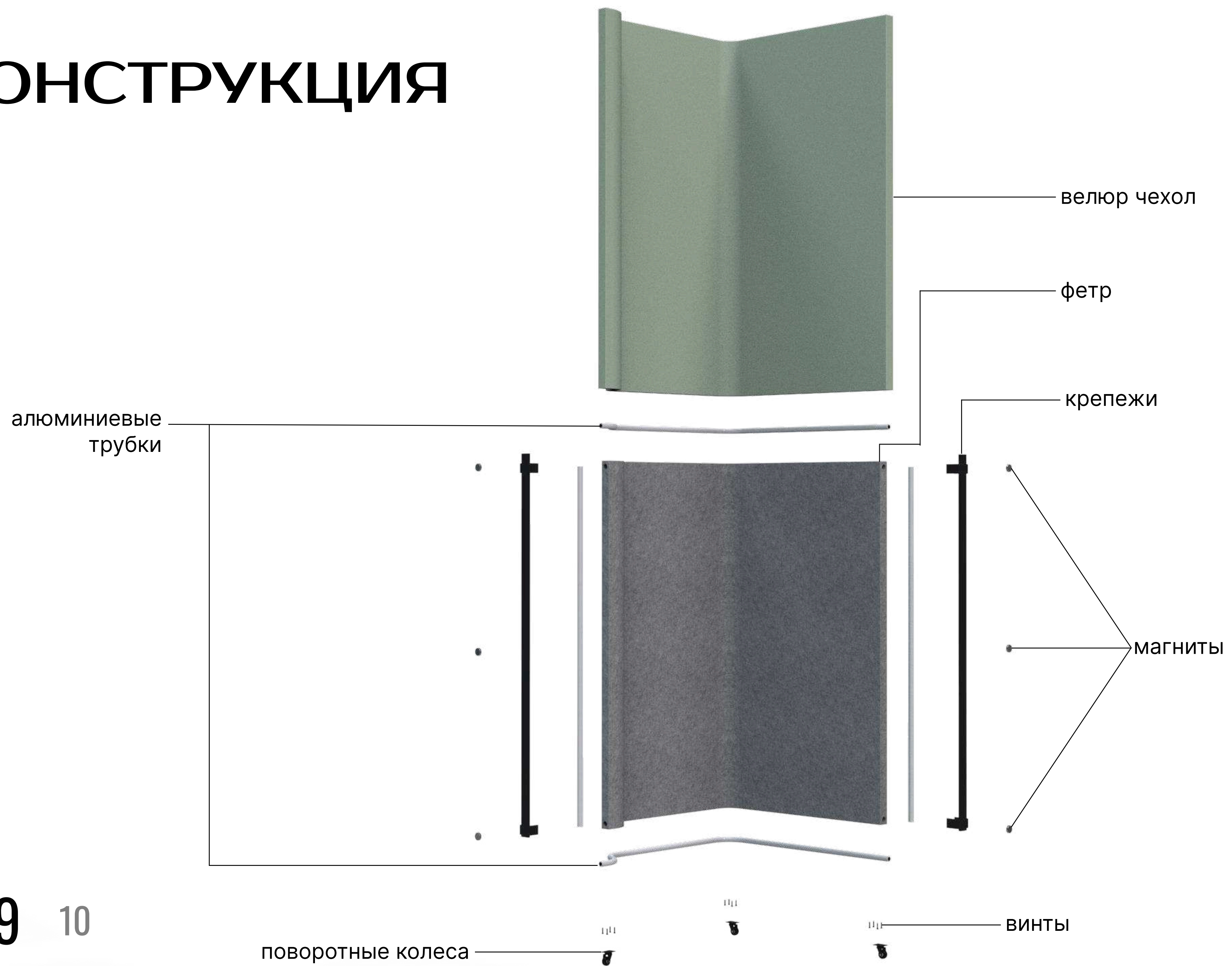



В СРЕДЕ

